

2500 HN series



www.martekpower.com

Dual Output DC/DC Converter



DESCRIPTIONS

The 2500HN, dual output power modules are 20 to 25 watt DC/DC converters available in a dual output configuration providing both digital and analog outputs in a compact, industry standard 2.0" X 1.6" X 0.4" package. These 400kHz, switching converters are available in 12, 24 and 48 VDC inputs making them one of the most versatile product lines in the market with efficiencies up to 87%. Advanced surface mount construction allows these converters to achieve outstanding thermal performance eliminating the need for thermal potting compounds and thereby enhancing manufacturing efficiency to reduce costs.

OUTPUT CHARACTERISTICS

	Min	Typ	Max	Unit/Comments
Output Voltage Set Point		±1		% Output voltage at nominal line & FL
Total Band Error	-3		+3	% Output voltage including line/load regulation setting
Line Regulation		±0.5		% Output voltage measured from min. input line to maximum
Load Regulation		±1		% Output voltage measured from FL to 10% load
Temperature Coefficient		±0.01		% per degree C
Ripple/Noise		60	100	mV p-p measured at 20 MHz bandwidth with external 1 µf capacitor
Output Voltage and Current				Refer to model selection chart
Load Transient Response		±2		% deviation of Vout voltage for a 25% load change for 200µS
Short Circuit Protection				Indefinite, Automatic Recovery
Output Voltage Trim Range		±10		% Output voltage
Overvoltage Protection		135		%; Clamp type

FEATURES

- Up to 87% Efficiency
- Dual Output, Up To 25 watt converter
- Available in 12, 24 and 48 VDC Inputs
- Industry Standard 2.0" X 1.6" X 0.4" Package
- Output Over Voltage, Input Over Voltage and Short Circuit Protection

INPUT CHARACTERISTICS

	Min	Typ	Max	Units/Comments
Input Voltage				
12 VDC Input Models	9	12	18	VDC
24 VDC Input Models	18	24	36	VDC
48 VDC Input Models	36	48	75	VDC
Under Voltage Shutdown				
12 VDC Input Models		8		VDC
24 VDC Input Models		17		VDC
48 VDC Input Models		33		VDC
Over Voltage Shutdown				
12 VDC Input Models		20		VDC
24 VDC Input Models		40		VDC
48 VDC Input Models		80		VDC
Full Load Input Current				
12 VDC Input Models			2.10	A
24 VDC Input Models			1.26	A
48 VDC Input Models			0.62	A
Input Fuse Requirements				
12 VDC Input Models			7	Amps; Slow blow type
24 VDC Input Models			4	Amps; Slow blow type
48 VDC Input Models			2	Amps; Slow blow type
Efficiency by Model				
2505D12HN		80		%; FL Nominal Line
2512D12HN		82		%; FL Nominal Line
2515D12HN		84		%; FL Nominal Line
2505D24HN		83		%; FL Nominal Line
2512D24HN		86		%; FL Nominal Line
2515D24HN		87		%; FL Nominal Line
2505D48HN		84		%; FL Nominal Line
2512D48HN		86		%; FL Nominal Line
2515D48HN		87		%; FL Nominal Line
Switching Frequency	360	400	440	kHz; Factory set
Remote Shut Down	Off	0	0.80	VDC; Referenced to input (-)
	On	3.5		VDC or open; Referenced to input (-)
Input - Output Capacitance			1000	pF
Input Filter				LC type
Isolation Voltage	1500			VDC
Isolation Resistance	100			MOhms

Martek Power reserves the right to change specifications without notice.

MODEL SELECTION CHART

	Input Voltage (VDC)	Output Voltage (VDC)	Full Load Output Current (A)
2505D12HN	12	±5	±2.00
2512D12HN	12	±12	±0.85
2515D12HN	12	±15	±0.67
2505D24HN	24	±5	±2.50
2512D24HN	24	±12	±1.00
2515D24HN	24	±15	±0.83
2505D48HN	48	±5	±2.50
2512D48HN	48	±12	±1.00
2515D48HN	48	±15	±0.83

GENERAL CHARACTERISTICS

	Min	Typ	Max	Unit/Comments
Operating Temp. Range	-40		+110	°C; measured at baseplate
Storage Temp. Range	-55		+125	°C; measured at baseplate
Material Flammability				UL94V-0
Altitude: Operating			10,000	Feet
Non-Operating			40,000	Feet
Relative Humidity	5		95	% Humidity, non-condensing
Weight			22	Grams
Size				2" X 1.6" X 0.4"
Case Material				Black coated aluminum
Agency Approvals				UL/CUL1950, TUV, EN60950

OUTLINE DRAWING

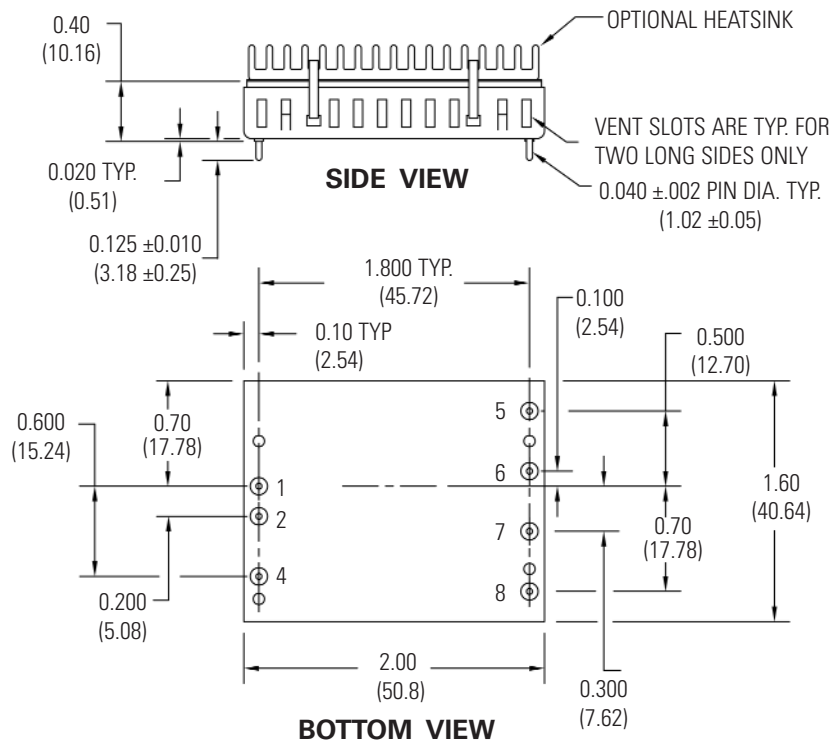

PIN OUT CHART

Pins	FUNCTION
1	+ INPUT
2	- INPUT
4	CONTROL
5	+ OUTPUT
6	COMMON
7	- OUTPUT
8	TRIM

Notes:

- Unless otherwise specified dimensions are in inches (mm).
- Controlling dimension in inch.
- Tolerances

Inches	mm
X.XX = ±0.02	X.X = ±0.5
X.XXX = ±0.010	X.XX = ±0.25

All specifications are typical at nominal input, nominal load and 25° C unless otherwise specified. External, low ESR, 33 microfarad (minimum) capacitor across output is recommended for operation.

How To ORDER

HOW TO ORDER

25 XX D XX HN - Y

Wattage ——— 25
 Output Voltage ——— XX
 Dual Output ——— D

XX ——— Input Voltage
 HN ——— Hi-Density, Non-Encap
 Y ——— ROHS Compliant

H Options: To add external heatsink mounted on the baseplate of the converter please add a “- H” at the end of the part number. Heatsink is provided to improve thermal performance (see derating curves).

DERATING CURVES

MODEL 2500HN Dual 3.3V & 5V (Without heatsink)

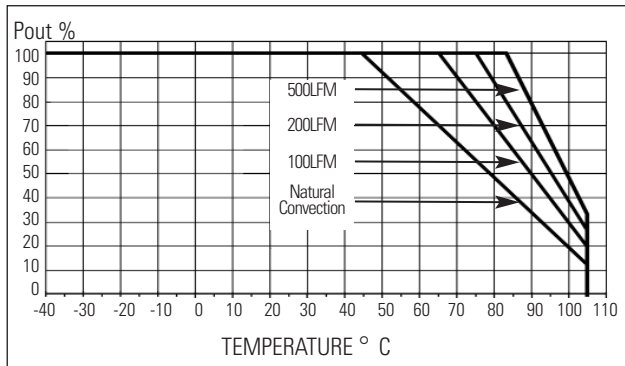

MODEL 2500HN Dual 3.3V & 5V (With heatsink)

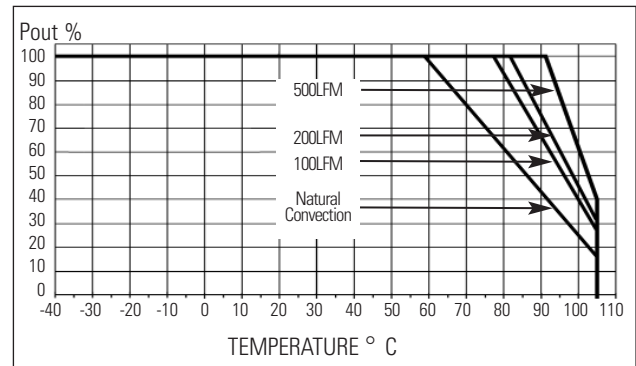

MODEL 2500HN Single 12V & 15V (Without heatsink)

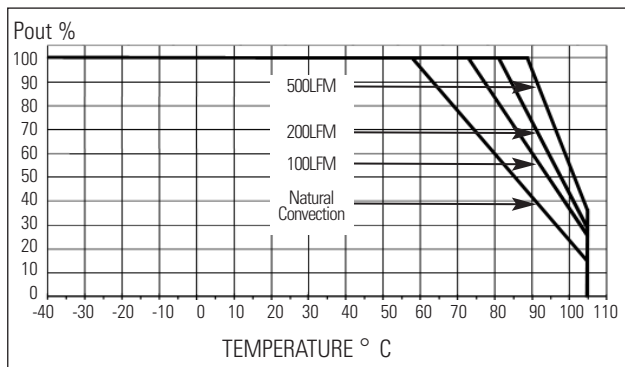

MODEL 2500HN Dual 12V & 15V (With heatsink)

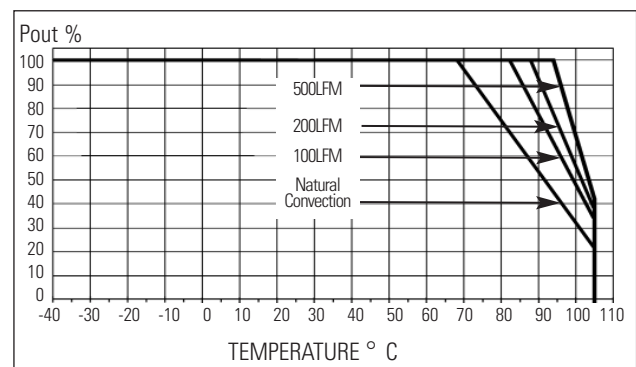

OUTPUT VOLTAGE ADJUSTMENT (2500HN DUAL SERIES)

The converter's output voltage may be trimmed by up to $\pm 10\%$ of the nominal output voltage.

TRIM UP

Trim output voltage up by connecting an external resistor between Pins 7 and 8. Use the following equation, reference Table 1 for variable A.

$$\text{Radj-up} = \frac{A}{\Delta \%} - 16 \text{ (k}\Omega\text{)}$$

Example:

Trim 5% up for 12V Output units,
where $A = 1.79$, $\Delta \% = 0.05$

$$\text{Radj-up} = \frac{1.79}{0.05} - 16 = 19.8 \text{ k}\Omega$$

Both outputs trimmed up by 5%.

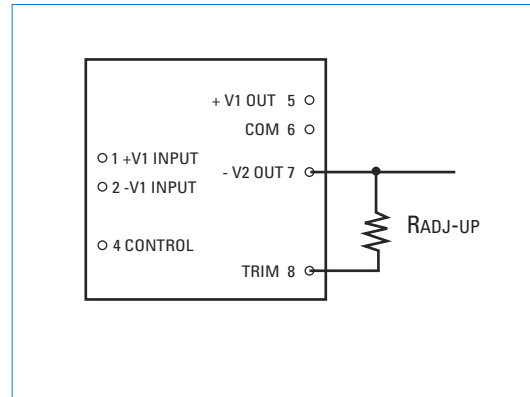

Table 1.

Output Voltage	A
$\pm 5V$	1.5
$\pm 12V$	1.79
$\pm 15V$	1.83

TRIM DOWN

Trim output voltage down by connecting an external resistor between Pins 5 and 8. Use the following equation, reference Table 2 for variables C and D.

$$\text{Radj-down} = \frac{C}{\Delta \%} - D \text{ (k}\Omega\text{)}$$

Example:

Trim 5% down for 5V Output units,
where $C = 4.5$, $D = 22$, $\Delta \% = 0.05$

$$\text{Radj-down} = \frac{4.5}{0.05} - 22 = 68 \text{ k}\Omega$$

Both outputs trimmed down by 5%.

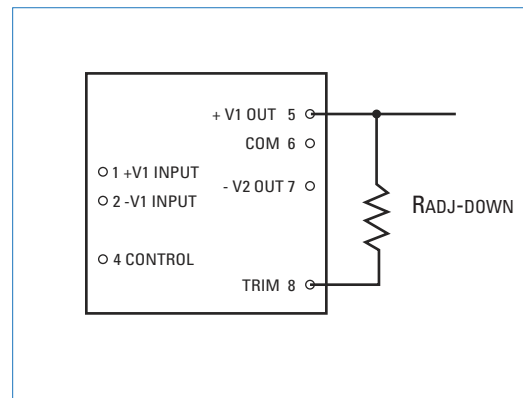

Table 2.

Output Voltage	C	D
$\pm 5V$	4.5	22
$\pm 12V$	15.4	33.2
$\pm 15V$	20.2	38